

# **MEASUREMENT, ANALYSIS AND INTERPRETATION OF VAGINA GEL COATING DISTRIBUTIONS IN WOMEN**

**David F. Katz, Ph.D.**

**Departments of Biomedical Engineering and  
Obstetrics and Gynecology  
Duke University**

- **The technology exists to image microbicide formulation distribution in the female reproductive tract (and rectum).**
- **How can we use this information to help development of effective microbicides products?**

# MICROBICIDE BIOFUNCTIONALITY

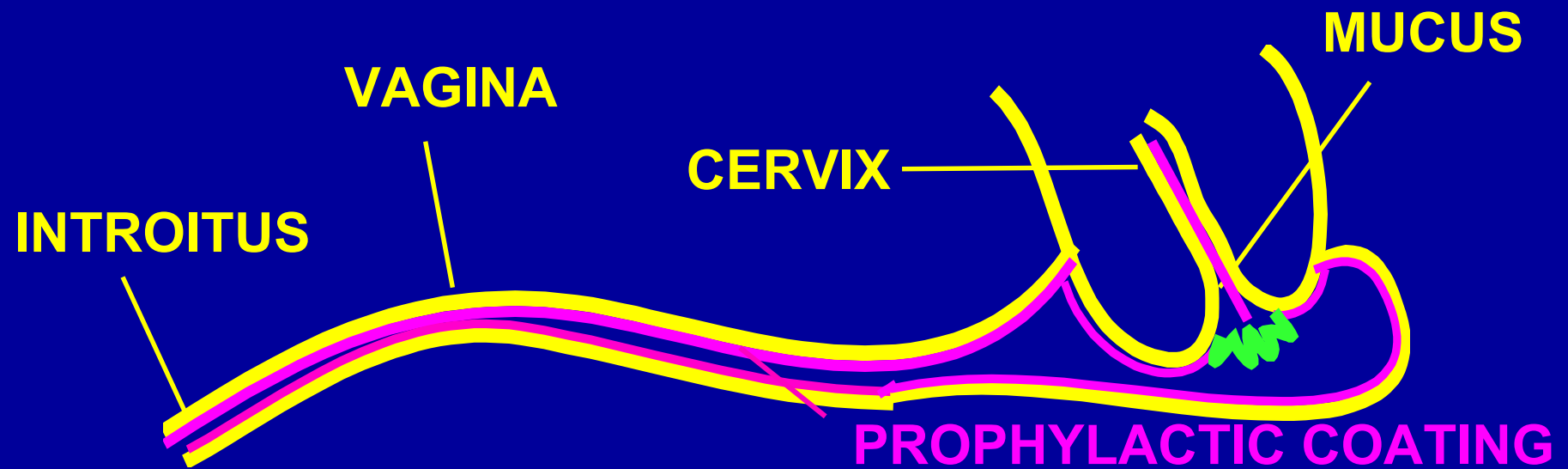

= **DEPLOYMENT** (distribution, retention)  
+ **DELIVERY**  
+ **BIOACTIVITY**  
+ **BARRIER**

- We assume that 'good' vaginal (and rectal) coating by microbicidal formulations is necessary for biofunctionality.
- We do not know what 'good' coating is:
  - *initial distribution*
  - *retention*
  - *properties of coating layer*
  - *concentration of active(s)*
- We must measure coating and attempt to understand its determinants.

# **Measuring vaginal coating**

---

- **Biologically relevant measurements**
- **Objective method**
- **Quantitative**
- **Accurate**
- **Precise**

# In situ methods of measuring vaginal/rectal distributions of formulations

---

- *Remote sensing*
  - **MRI**
  - **Gamma scintigraphy**
  - Other
- *Internal measurement - endoscopic devices*
  - **Fluorescent labels on formulations**
  - Natural luminescence
  - Optical coherence tomography

# Optical Vaginal Scanning Technique

---

- **Fiberoptic (endoscope) encased in transparent phallish-shaped insertion device**
- **Formulation labeled with Na-Fluorescein**
- **Linear correlation between fluorescence intensity and local thickness of coating layer**
- **35 - 50  $\mu\text{m}$  spatial resolution of thickness**
- **Systematically map coating over vaginal surface adjacent to tube (inside of cylinder) using local fluorimetric readings and video images**

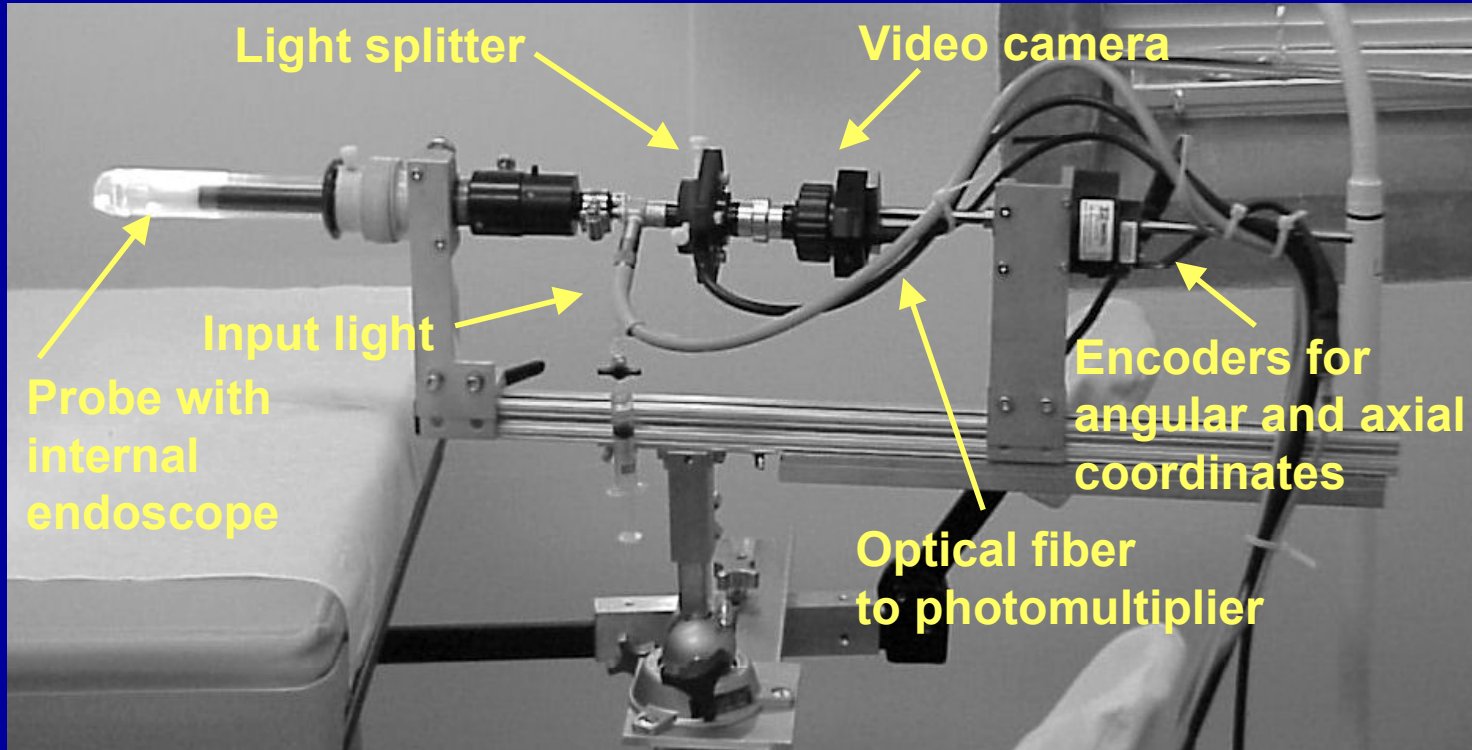

**Photo of optical scanning device, with frame for positioning/securing to examination table**

# Gel Thickness Distribution (Conceptrol)

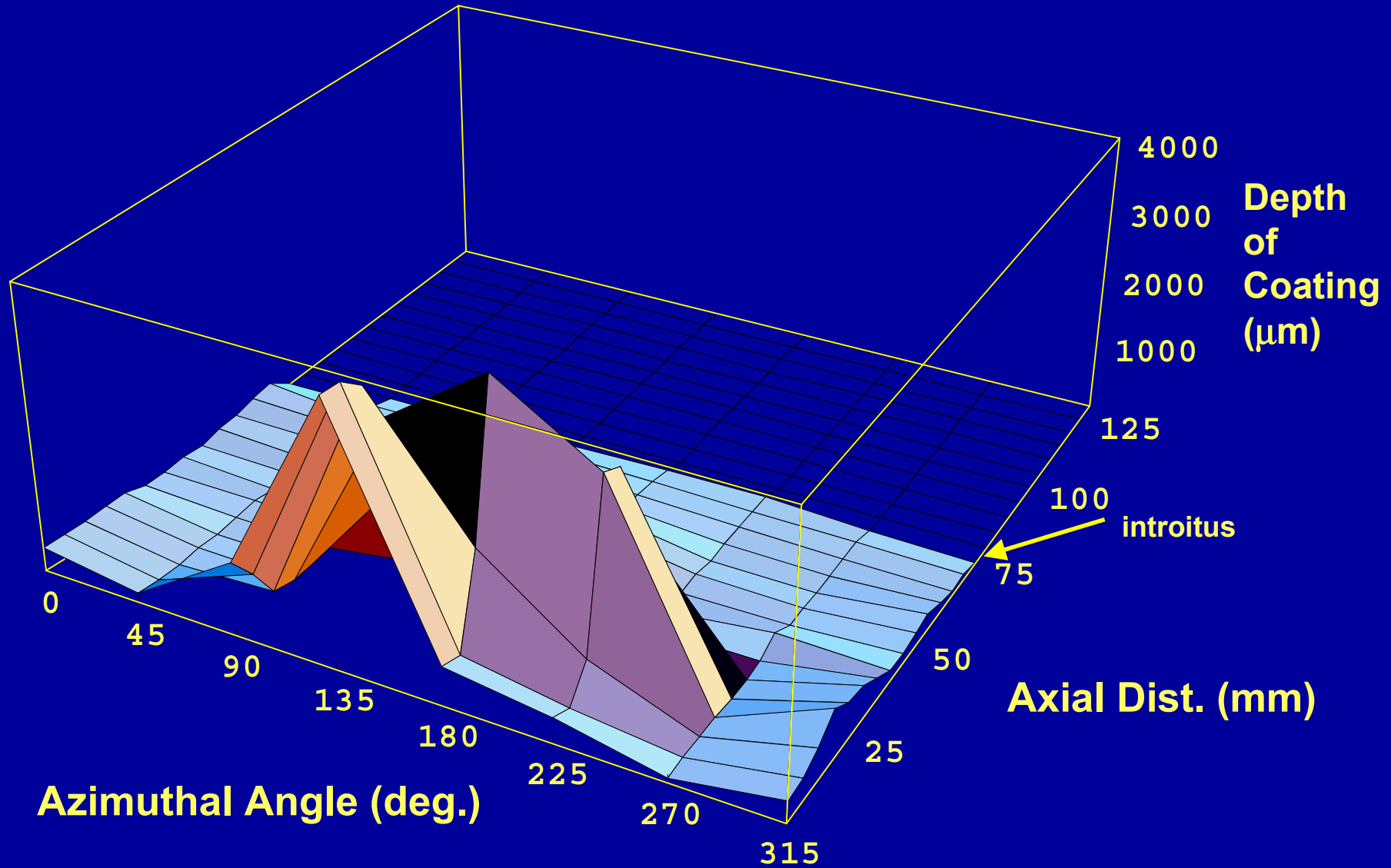

# What are biologically important characteristics of formulation distributions within the vagina or rectum?

- Extent

- What fraction of the vaginal/rectal surface/volume contains detectable formulation?
- How thick is the local coating?

- Location

- Where is/isn't the formulation in the vagina/rectum?

- Uniformity/variability/continuity

- How smooth is the distribution?
- Are there bare spots?

# VAGINAL COATING THICKNESS DISTRIBUTION OF CONCEPTROL

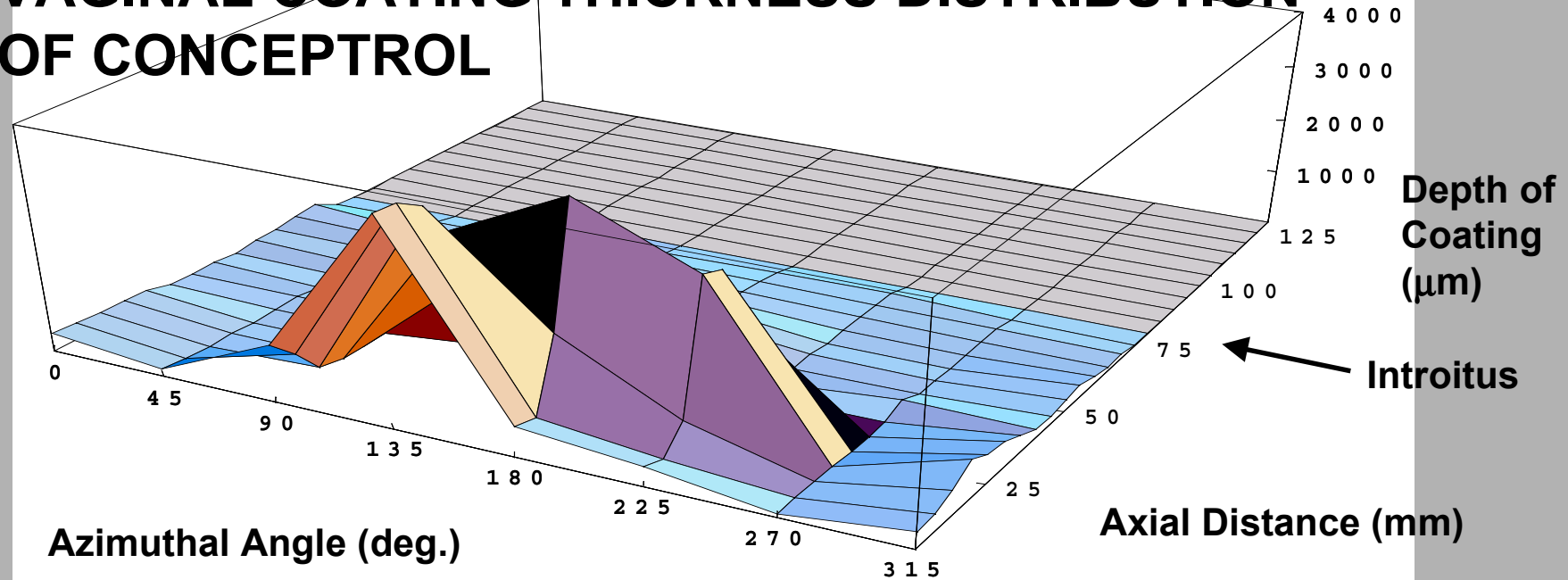

<b>Volume Inserted (ml):</b>	<b>3.25</b>
<b>Percentage of volume distal to fornix:</b>	<b>21.2%</b>
<b>Percentage of area covered:</b>	<b>69.0%</b>
<b>Overall average coating thickness (mm):</b>	<b>0.160</b>
<b>Position of center of mass of coating (mm):</b>	<b>14.93</b>
<b>Coefficient of variation of distribution thickness</b>	<b>1.88</b>

# VAGINAL COATING THICKNESS DISTRIBUTION OF ADVANTAGE

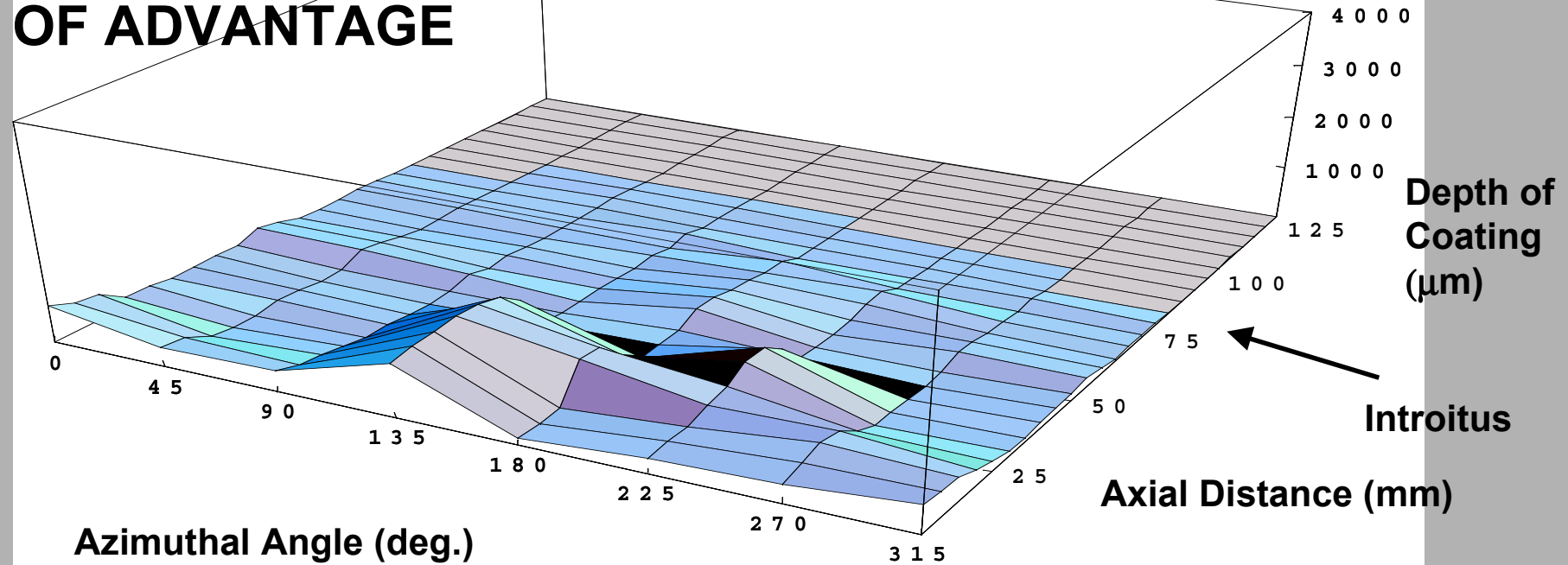

<b>Volume Inserted (ml):</b>	<b>3.12</b>
<b>Percentage of volume distal to fornix:</b>	<b>47.2%</b>
<b>Percentage of area covered:</b>	<b>99.3%</b>
<b>Overall average coating thickness (mm):</b>	<b>0.200</b>
<b>Position of center of mass of coating (mm):</b>	<b>22.54</b>
<b>Coefficient of variation of distribution thickness:</b>	<b>1.30</b>

# Percent of Coated Area having a Gel Thickness $\geq$ Specific Value

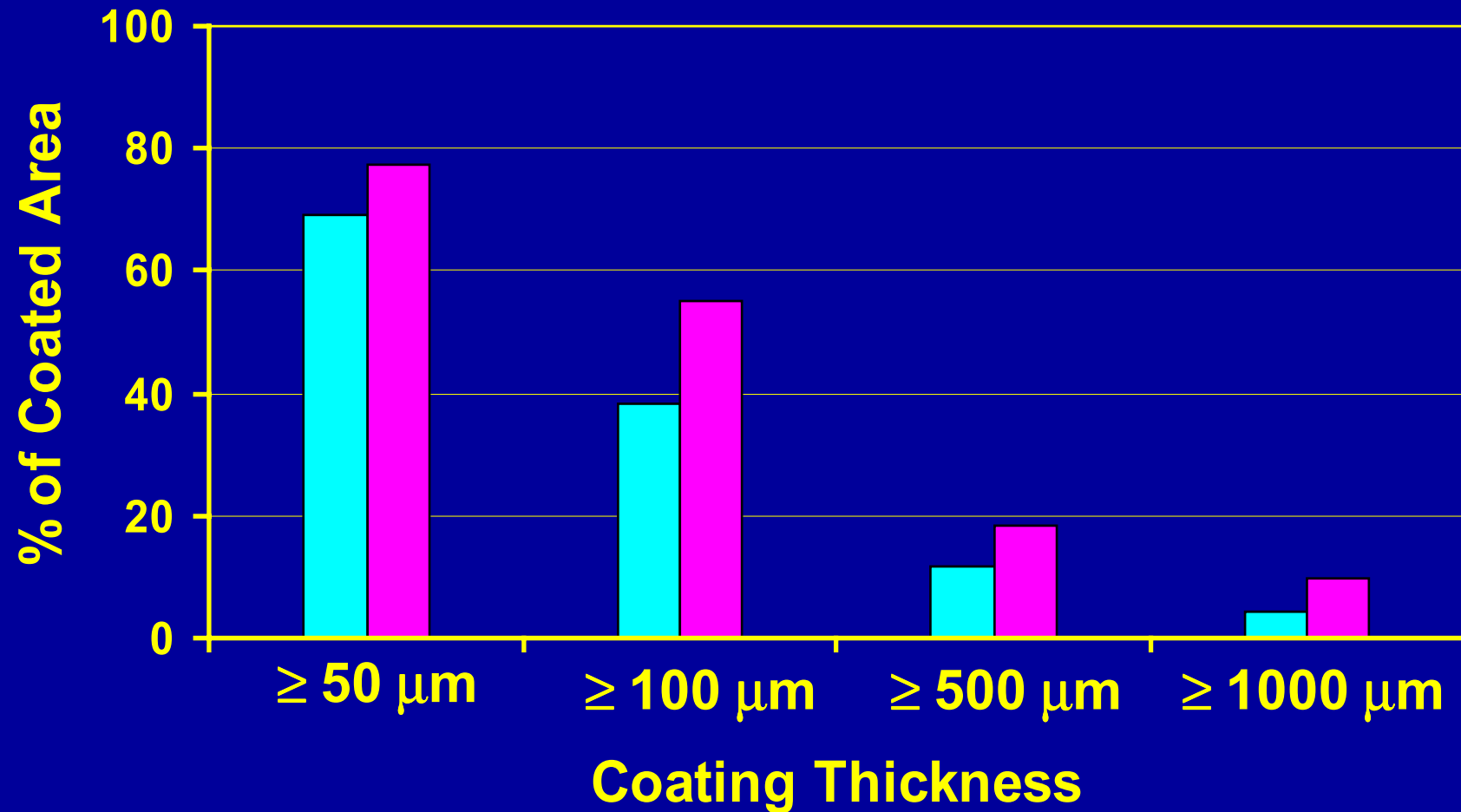

■ Conceptrol (n=9)

■ Advantage (n=14)

# Axial and Angular Dependence of Coating Thickness Distribution

## Conceptrol

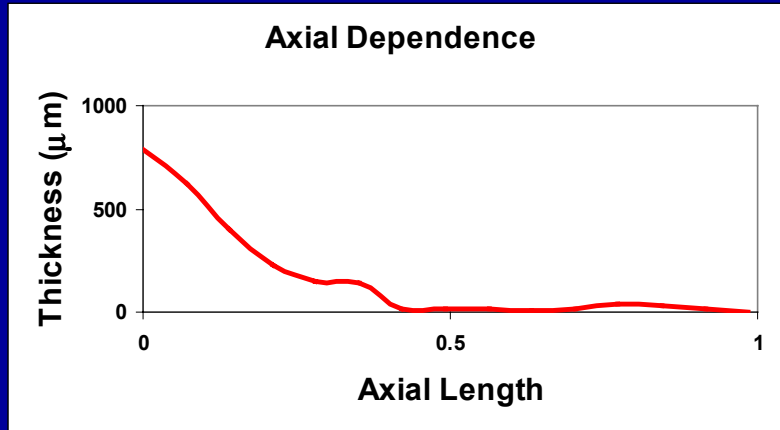

## Advantage

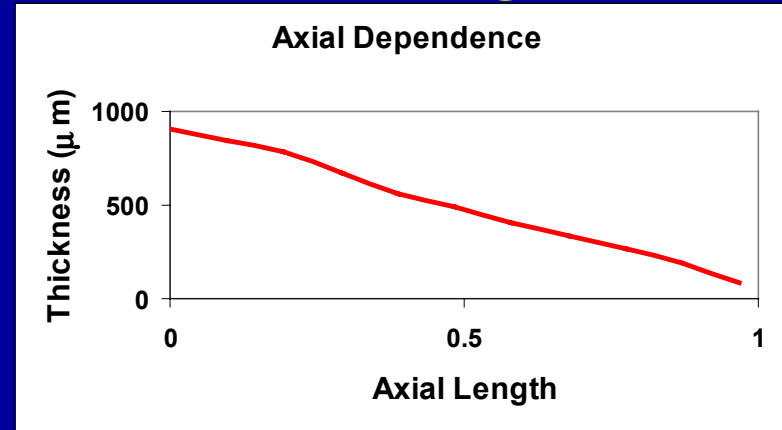

**Angular Dependence  
Thickness in microns**

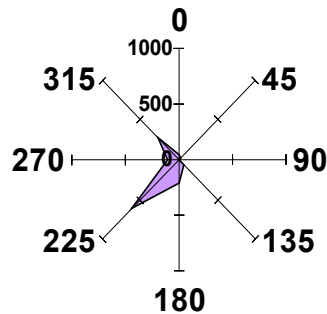

**% Volume Distal  
to Fornix**

**39% | 85%**

**% of Area Coated**

**36% | 100%**

**Angular Dependence  
Thickness in microns**

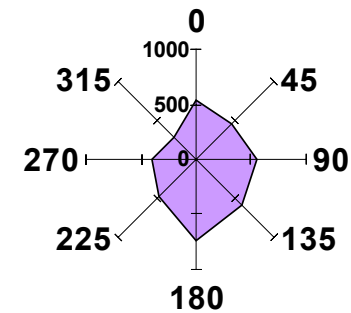

**Are there differences in coating:**

- between formulations?**
- between conditions of application?**

- What differences are there?**
- How big are they?**
- How *'big'* is important?**

N	Conceptrol		Advantage	
	<i>Recumbent</i>	<i>Sit-Stand-Sit</i>	<i>Recumbent</i>	<i>Sit-Stand-Sit</i>
	8	9	9	11
<b>% Coated*</b>	74 ± 8	84 ± 6	96 ± 2	95 ± 5
<b>%&gt;100 μm*</b>	30 ± 7	54 ± 11	54 ± 5	77 ± 12
<b>%&gt;400μm</b>	10 ± 3	30 ± 8	19 ± 4	35 ± 7
<b>Xcm/L*</b>	.19 ± .03	.26 ± .03	.23 ± .02	.35 ± .04
<b>% Distal</b>	22 ± 7	52 ± 11	38 ± 5	42 ± 7
<b>Coeff Var*</b>	1.75 ± .14	1.15 ± .20	1.23 ± .09	.83 ± .15

\* Conceptrol □ Advantage

## **Between Women Variabilities\* for Different Coating Measures**

**% volume distal to fornix .56**

**% scanned area with coating .25**

**Center of mass (axial) .31**

**Spatial coefficient of variation .32**

**\* values averaged for Conceptrol & Advantage,  
expressed as *coefficients of variation*  
between women**

# Strengths and Weaknesses of the Optical Technique

- High spatial resolution
- Potential for visualizing “bare spots”
- Relatively inexpensive and logistically easy
- Potential to measure local properties of coating layer and local concentration of active(s)
- Requires standardization of device insertion
- Device insertion alters original formulation distribution (~ penis?)
- Single measurement per experiment

## **Measurement of vaginal distribution/retention of topical formulations**

---

- **What is measured?**
- **Accuracy - spatial resolution**
- **Precision - repeatability**
- **Data reduction and analysis**
- **Instrument maintenance/durability**
- **Logistics - timing, location, personnel needed**
- **Human acceptability**
- **Cost**

# MICROBICIDE BIOFUNCTIONALITY

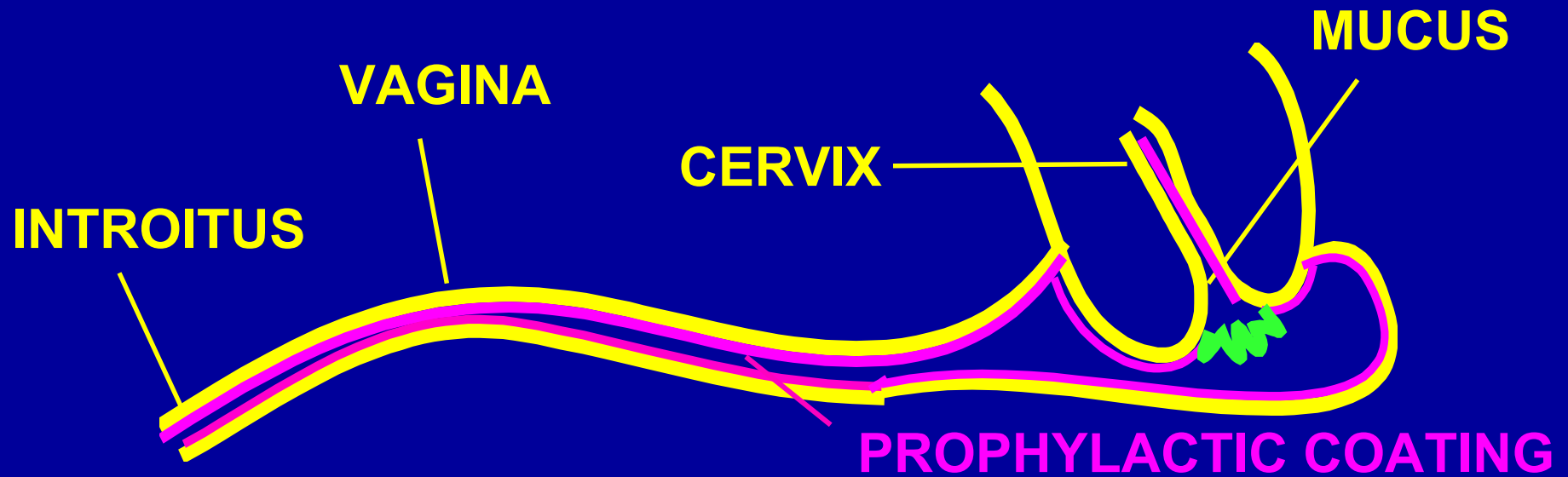

= DEPLOYMENT (distribution, retention)  
+ DELIVERY  
+ BIOACTIVITY  
+ BARRIER

Acknowledgement: CONRAD; amfAR, FDA, NIH